

everis

an NTT DATA Company

About everis Aerospace and Defense



everis Aerospace & Defense

Innovative and reliable technologies offering the best capabilities to our clients

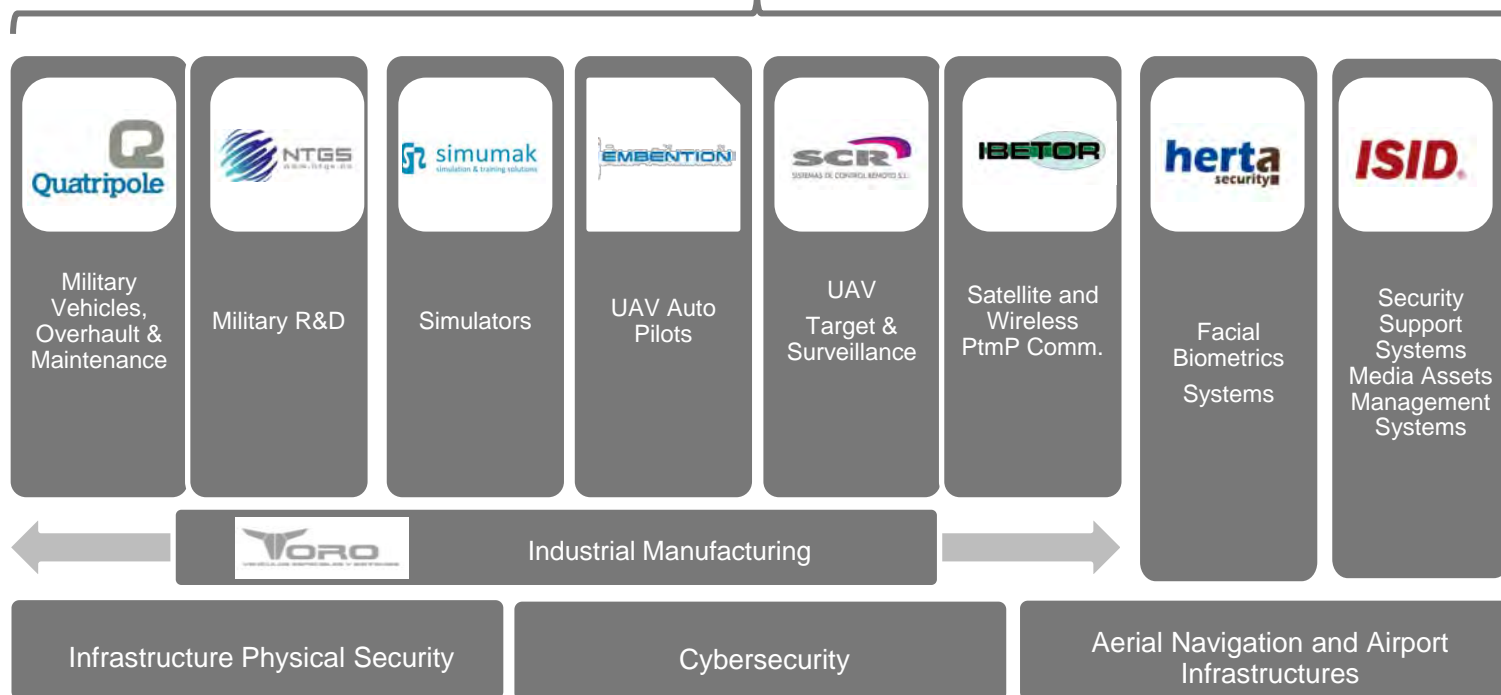

Mortar Carrier Challenge

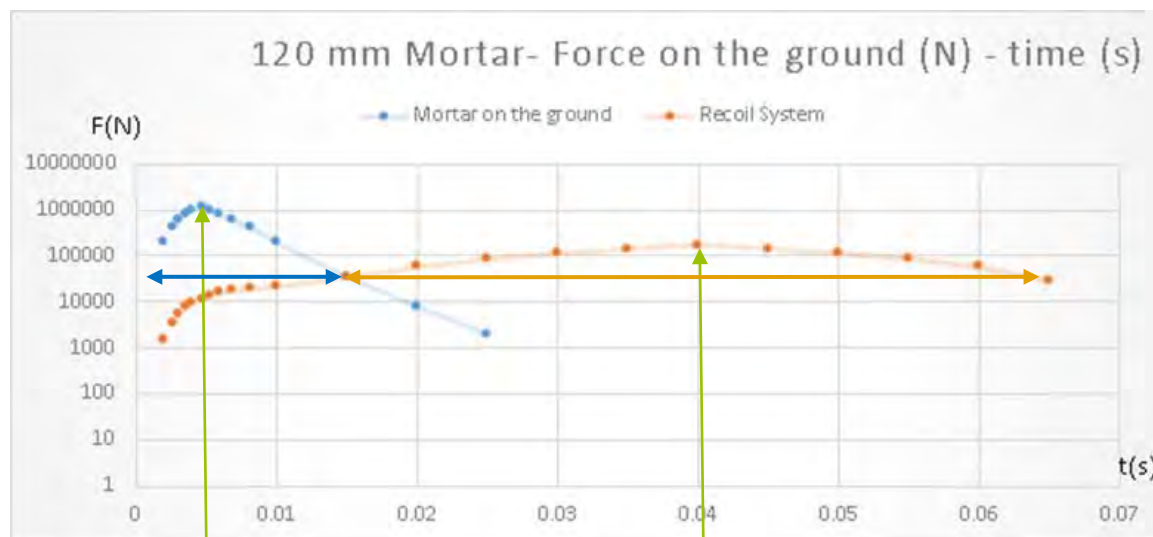

Peak Recoil Force 120 Tons during 0,001 sec.*

Peak Recoil Force 30 Tons during 0.01 sec.**

* Measurement based 120 mm mortar from ECIA with 7 supplements (full charge)

** Based on information about SRAMS (first to achieve only 30Tons recoil force)

Mortar Carrier Challenge

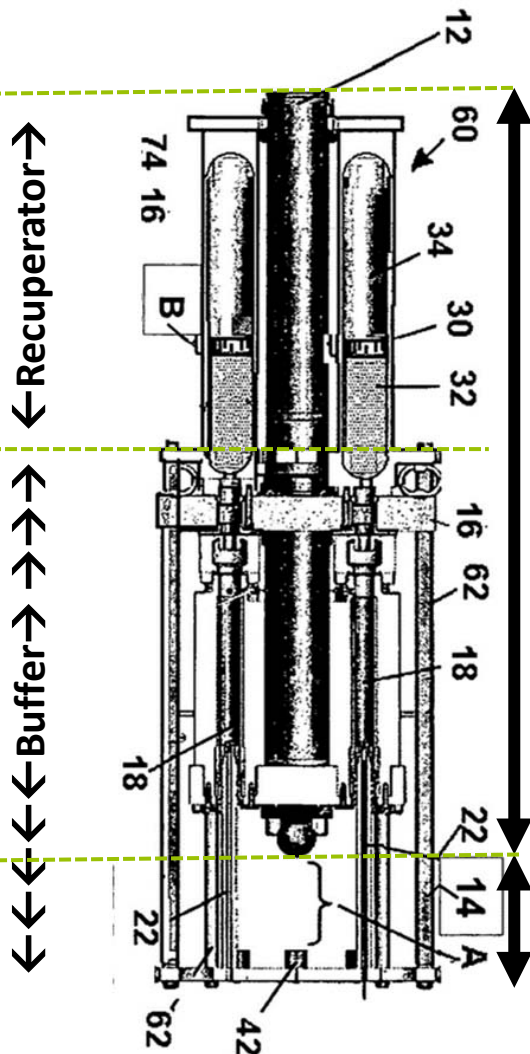

Shooting energy ... approx. 500,000 Jules

- **Transmitted to the vehicle** \approx 100,000 Jules
- **Absorbed** \approx 400,000 Jules

But... “Energy can neither be created nor destroyed”

- **Absorbed** \approx 400,000 Jules \approx 100,000 Cal



Non dissipated energy, together with the absorber structure limit the system capability for iterative shooting (cook-off)

* Recoil absorber. <http://www.google.com.tr/patents/EP2400255A2?cl=en>

Mortar Carrier Challenge

Effect on the vehicle

Peak Recoil Force 30 Tons during 0.01 sec
This is equivalent to 10 Humvees with their crew.



Mortar Recoil Absorber Limitations

- Increase height (Difficult loading)
- Over heating and limited repetitive shooting (Cooking-off)
- Limited aiming capabilities ($+30^{\circ}/-30^{\circ}$)
- Limited operation space
- Requires structural reinforcement
- Requires hydraulic jacks
- Heavy solution (limited available payload for ammunition)
- Only feasible in very large and expensive vehicles.

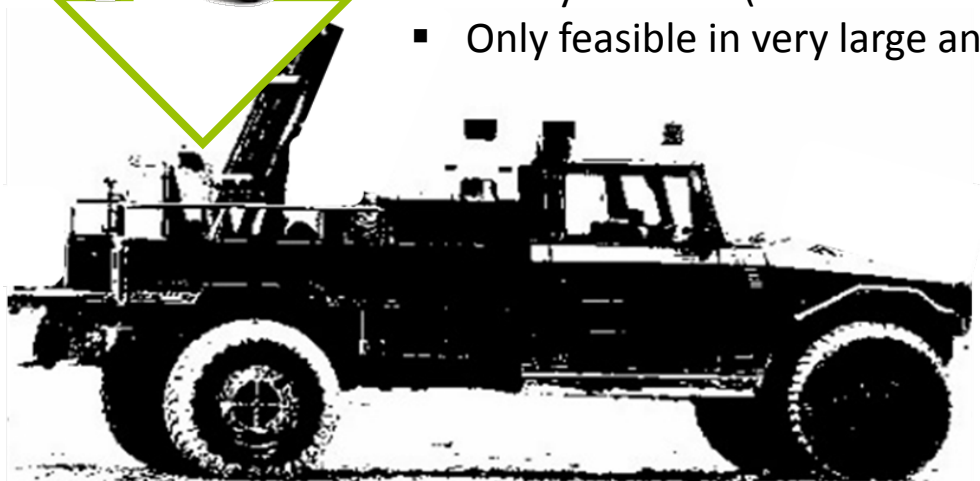

ALAKRAN MORTAR CARRIER

ALAKRAN Mortar Carrier System brings a different perspective to the standard recoil absorber approach.

- Simpler, Smarter and more common sense solution.

Shooting from the ground with an automatic control and aiming from the vehicle.



←←←←← 12 seconds to deliver fire power →→→→→/←←← 5 seconds out of action →→→

Some achievements

We have developed the world fastest and most rewarded facial recognition system.

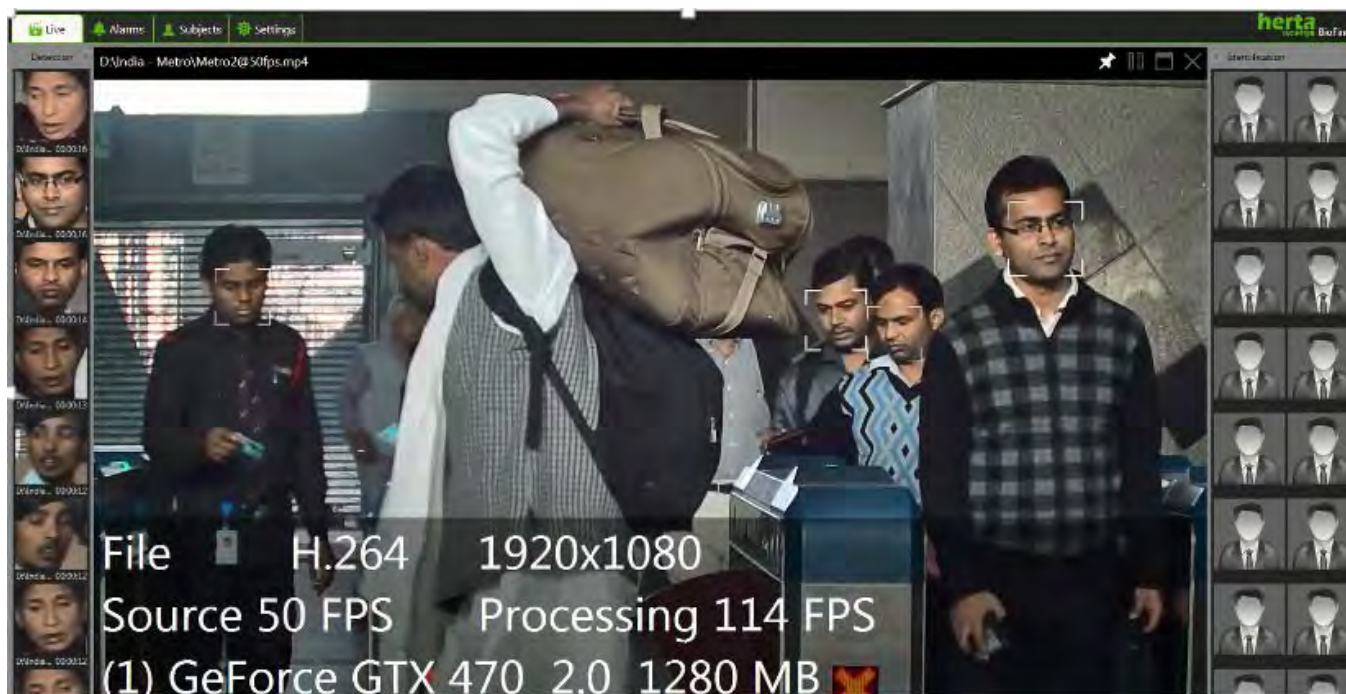

ECS Award Winner 2015
GPU Technology Conference



Herta Technology Algorithms

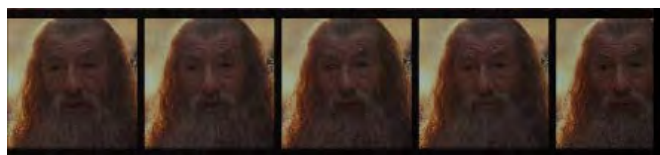
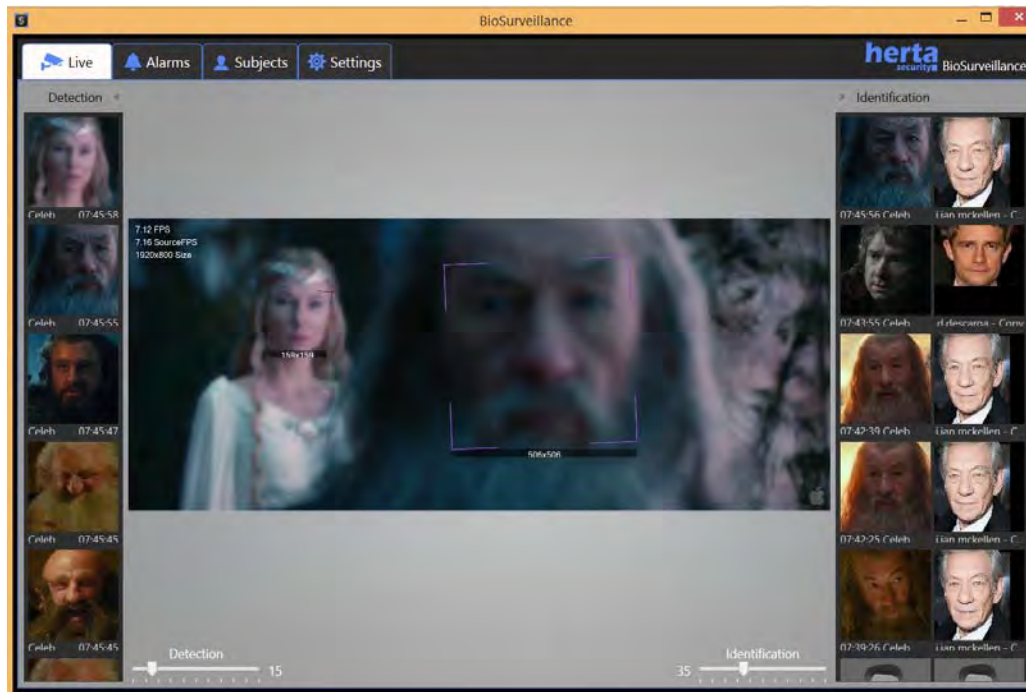

Faces detection algorithm



Every face detected is sent to the identification algorithm

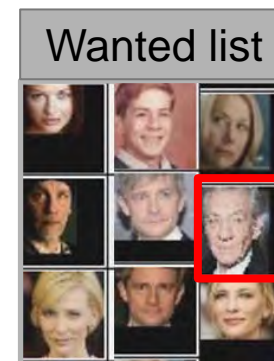

Identification algorithm

Video Management vs Photo Management

Accuracy

Video (approx. 24 frames per second)



Working with video will provide many identification chances. 3 second video will provide about 72 images to be compared.



Meanwhile working with photos will give us only 1 identification chance.

To be successful in photos identification we need to work with really high quality photos in the “wanted list photo set” and the “analysis photo set”.



Video Management vs Photo Management

Good quality photo –passport photo

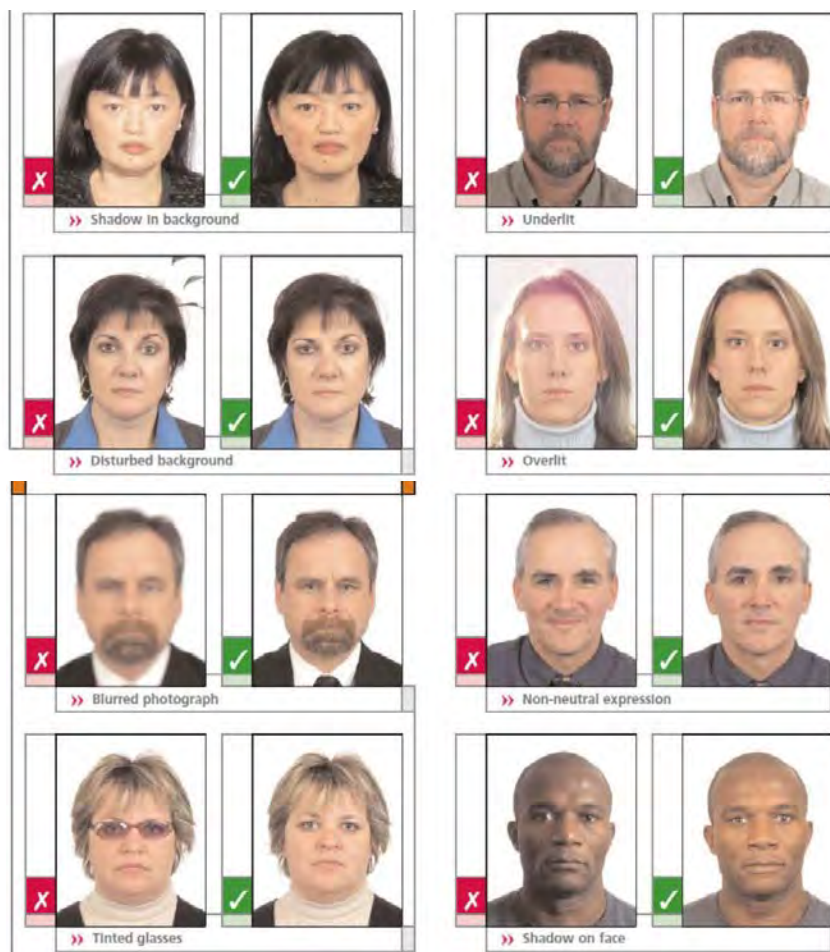
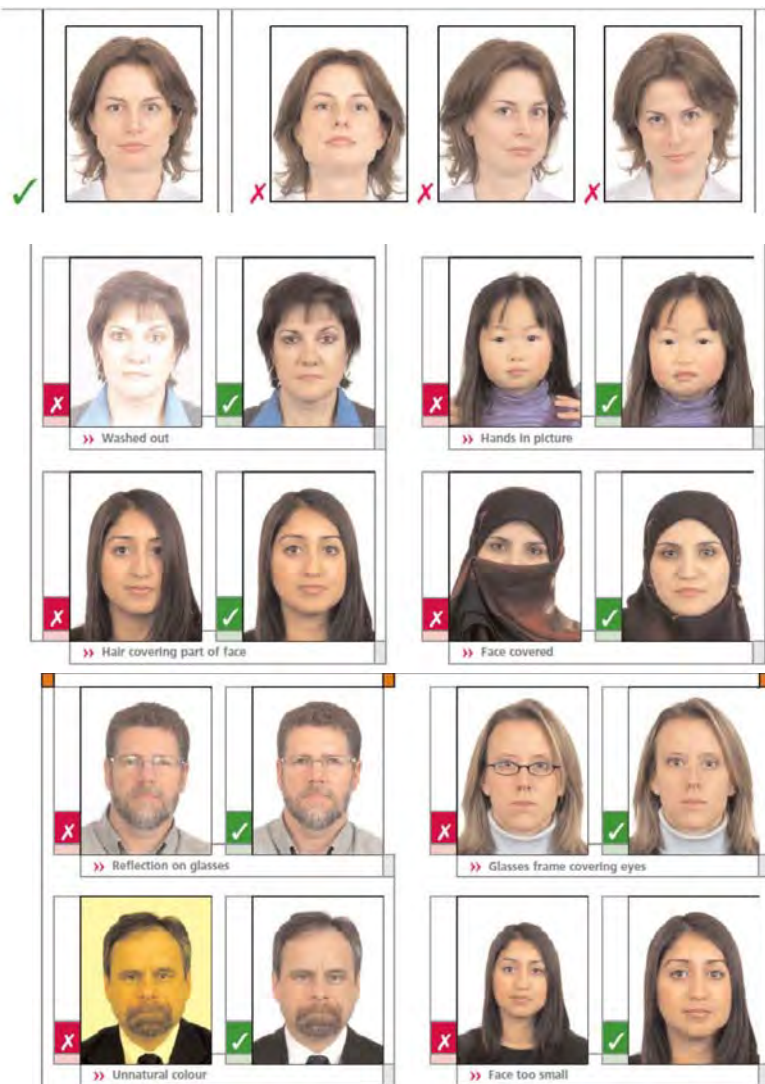

Good quality photos will provide good identification results.
Bad quality photos will provide false positives or non-identification



an **NTT DATA** Company

everis.com

Consulting, IT & Outsourcing Professional Services